

PHRF-SEF 2009 Rating Rules

BASE RATINGS

Established base ratings can only be changed by a majority vote of the handicappers at a Board of Handicappers meeting. A quorum for the Board of Handicappers is a simple majority of the handicappers with a minimum of four (4).

Since PHRF assumes that a boat is equipped to race, no credit in rating will be given to partially equipped boats, unusually heavy boats (as live aboards), boats with unusual windage.

Established base ratings can only be changed by a majority vote of the handicappers at a Board of Handicappers meeting. A quorum for the Board of Handicappers is a simple majority of the handicappers with a minimum of four (4).

PHRF/SEF does not specify safety equipment. It is recommended that race organizers utilize the ORC Special Regulations and/or applicable U.S. Coast Guard regulations.

A crew limit is provided on the certificate. Currently PHRF/SEF does not require adherence to crew limits to maintain validity of handicap. Some race organizers may invoke crew limits in the *Notice of Race* or *Sailing Instructions*, in which the crew limit is provided for that purpose. If weight limits are imposed we assume 180 pounds per crew person.

DEFINITIONS

STAYSAIL	-Clew shall not extend past rated LP line of the boat.
BLOOPER	-Defined as a headsail. Can sail with no penalty if within the LP measurement of the genoa.
FLASHER -(or Cruising Chute)	Rated as if with a spinnaker.
JIB	-Any sail tacked forward of the foremast with a half width not exceeding 75% of the foot length is a jib.
SPINNAKER	-Any other sail tacked fwd of the foremast (and not meeting the definition of a jib) is a spinnaker.

Listing of standard Credits:

Credits not listed here can and will be taken into consideration on a case by case basis with proper documentation supplied by applicant.

1. HEADSAILS

Headsail: Any sail tacked forward of the foremast that is flown with the luff attached to a stay or otherwise not free-flown is a headsail. Any sail tacked forward of the foremast

with a half width not exceeding 75% of the foot length with a free-flying luff is also a headsail. The boat's largest headsail will be rated by computing 100 times LP divided by J, where LP is the distance of a line perpendicular from the luff, to the clew. Boats carrying largest headsails with LP in excess of 100% , with battens or other stiffening devices shall declare that fact to PHRF SEF, and provide the measurements of the HHW, Luff, Leech, Foot and LP of the largest headsail. Headsails with LP in excess of J, with battens or stiffening devices will be rated on an individual basis.

Headsails: Luff Length LL

Luff Perpendicular LP

Half Width HHW (for headsails with roach on leech)

1. GENOA SIZE

A.

Headsail LP shall not exceed 1.55 x J without a rating adjustment

The LP line is defined as a line abaft of and parallel to the foremost headstay and separated from it by the LP dimension declared in the rating certificate. The foremost headstay is defined as the line joining the upper measurement point of "I" and the forward point of "J" (not "JC").

	<u>Sec/Mile</u>
LP up to 156 - 180%.....	-6
LP up to 136 - 155%.....	0
LP up to 106 - 135%.....	+6
LP less than 105%.....	+9

Further limitation: no jib may be set in conjunction with any other headsail so as by any means to simulate a double clewed or double luffed jib. (For example, no two jibs may be carried simultaneously in a jib groove device, except briefly while changing sails).

These above Credits/Penalties only apply to boats that have been modified from there stock configuration.

Modification of (J) measurement

Increase or decrease JPer review of the Board of Handicappers

Roller furling Credits

HEADSAIL CREDITS: If you race with one or more Roller Furling headsail(s) that are **(MUST MEET ALL CRITERIA)**:

RF Credit (+ 3 sec/mi)

short hoist (i.e., its luff length is **at least 2.5% of the I measurement** shorter than the headstay length (Headstay length is measured from deck sheer line to mast) attached to a bottom drum and top swivel and regularly used at the primary racing headsails, and is roller furled during racing (Note: any number of headsails 110% or smaller, roller furling or non-roller furling can be used as appropriate)

RF Cruising Headsail Credit (+ 9 sec/mi)

If you race with a roller furling headsail that meets **all** of the above ‘ ’ ROLLER FURLING HEADSAIL CREDIT” criteria, **and, in addition (MUST MEET ALL CRITERIA)** :

is the only headsail greater than 110% LP used for racing (Note: any number of headsails 110% or smaller, roller furling or non-roller furling can be used as appropriate) is regularly stored on the headstay when the boat is not racing or sailing is regularly used as the primary genoa when the boat is day sailing and/or cruising has a UV material leach cover attached to the sail (e.g. stitched or glued) ***all head sails must be of a woven polyester material (no exotic sail materials such as pentax, mylar, kevlar, spectra, technora, etc.)***

2. MAINSAILS

	<u>Sec/Mile</u>
Mainsails meeting the measurement requirements	0
Oversized Mainsails	Per review of the Board of Handicappers

Measurement of mainsails

2A. No constraints shall be imposed on batten lengths or number.

2B. The foot of mainsail (E) shall be the length measured along the boom, from the aft edge of the mast to the aft most point to which the sail is permitted to extend. Where this aft most point is inside of the boom end, it shall be located by the inner edge of a one inch black band around the boom.

2C. Mainsail hoist (P) shall be the measured length of the hoist of the sail. It is the distance along the after side of the mainmast from the highest level to which the head of the sail may be set to the lowest position of the tack. The highest point shall be taken at the lower edge of the required one-inch wide measurement band around the mast. The lower point is defined as the intersection of the boom and the mast (respective aft and top parts).

If a sliding gooseneck is used, measurement is to be made with the boom at the extreme bottom of the slide unless the lowest sailing position of the foot is marked by the upper edge of the required one-inch wide measurement band around the mast at the gooseneck.

2D. The mainsail head width length (HW) shall be the maximum fore and aft dimension from the luff of the main, projected if necessary, to the extreme edge of the leech of the main measured across the widest part of the headboard. HW is limited to the greater of (.04 x E) or 0.5 feet.

Rated without adjustment are the maximum mainsail girths:

MGT (7/8 leech) = $0.22 * E$

MGU (3/4 leech) = $0.38 * E$

MGM (1/2 leech) = $0.65 * E$

MGL (1/4 leech) = $0.90 * E$

Mainsails exceeding any of the above girth measurements are subject to a rating adjustment.

Mainsail Dimensions & Folding for Girth Measurements:

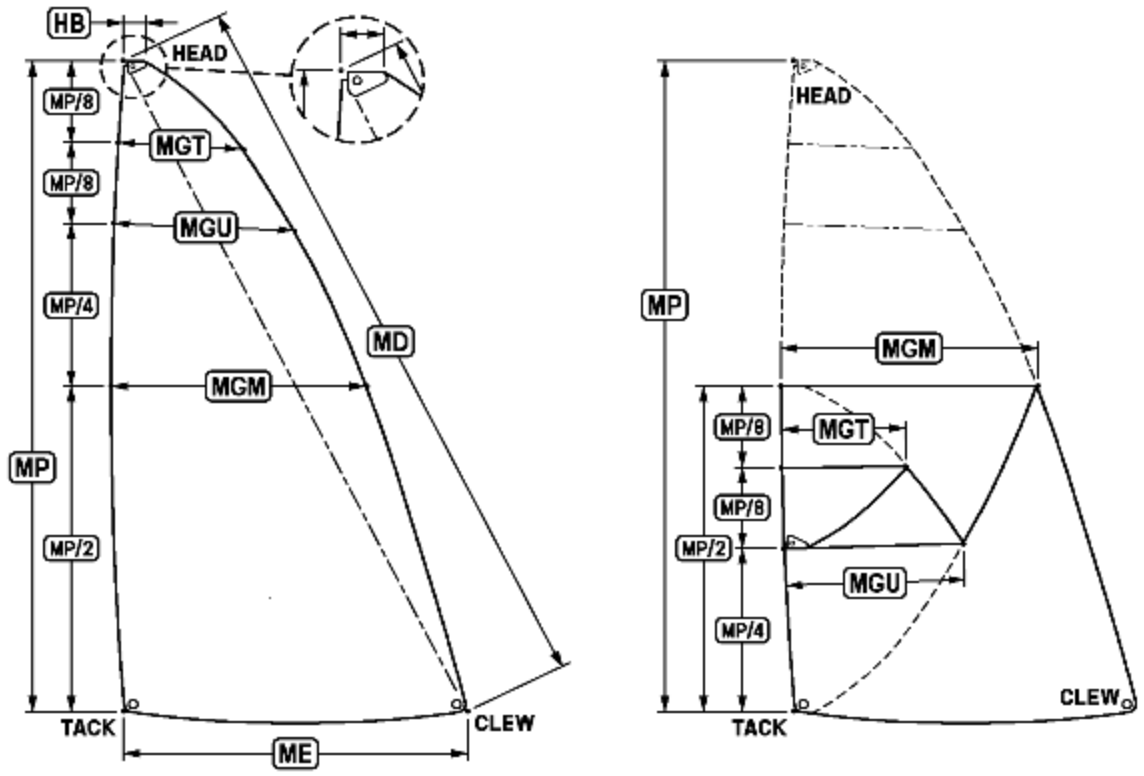

Oversized mainsails defined by the Vessels class racing rules or Yacht designer in which the yachts base rating already factors the oversize mainsail into the base rating are not subject to rating penalties. Proof of such documentation must be submitted by applicant to be exempt of any rating adjustments.

2D. Spare mainsails are not permitted to be carried on board. Tri-sail storm sail are exempt and is permitted.

2E. Black Bands shall be present on both the Mast and Boom marking the max measurements defined. The max measurement shall be the inner edge of the Black Band.

- Modification of (E) up to 10%..... +/- 3 sec/mile
- Modification of (E) up to 20%..... +/- 6 sec/mile
- Modification of (E) over 20%Per review of the Board of Handicappers

- Modification of (P) up to 5%..... +/- 3 sec/mile
- Modification of (P) up to 10%..... +/- 6 sec/mile
- Modification of (P) over 10%..... Per review of the Board of Handicappers

- Oversize Roach (including increased area).....Per review of the Board of Handicappers

- Hollow Leach with out battens..... +6 sec/mile

3. SPINNAKERS

Measurement

Declaration shall be of the largest spinnaker carried. PHRF-SEF does not limit the number of spinnakers permitted on board.

General

- A. Spinnaker Maximum Width (SMW) shall be at the foot or across the body of the sail, measured between points on the luffs equidistant from the head.
- B. Spinnaker Luff (SL) shall be the greatest length of spinnaker luff and leech measured around the edges of the sail.
- C. Spinnaker Foot (SF) shall be a distance from tack to clew measured in the shortest path on the surface of the sail.
- D. Spinnaker Midgirth (SMG) shall be the distance between the midpoints of luffs measured in the shortest path across the sail. Shall not exceed 1.8 X J.
- E. Mid Girths greater than 75% of the foot. Less than 75% the sail is treated as a headsail.
- F. Symmetric Spinnaker Luff (SL) or Leach length shall not exceed .95 times the square root of $(I^2 + J^2)$ without penalty.

NS No spinnaker credit+9 sec/mile

Spinnakers: Luff Length SLU

- Leech Length SLE
- Foot Length SF
- Mid Girth SMG
- Pole Length SPL (mast to tip of spin pole)

Spinnaker: Any other loose luffed sail tacked forward of the foremast, with mid girth exceeding 75% of the foot length is a spinnaker. A Spinnaker is symmetrical if the luff and leech differ in length by four percent or less, and asymmetrical if the luff and leech lengths differ by more than four percent. Spinnaker maximum width is 180% of SPL, where SPL is the length reported for the spinnaker pole or bowsprit to which the spinnaker will be attached, with maximum girth measured from the midpoint of the spinnaker luff to the midpoint of the spinnaker leech. Symmetrical spinnaker maximum luff length shall not exceed $.95 * \text{SQRT}(I^2 + \text{SPL}^2)$ or (if applicable), $.95 * \text{SQRT}(\text{ISP}^2 + \text{SPL}^2)$. Asymmetrical spinnaker square footage will not exceed the area of the largest symmetrical spinnaker that could be carried by the same boat, determined by the following formula: Spinnaker Area = $((\text{SLU} + \text{SLE})/2) * ((\text{SF} + (4 * \text{SMG}))/5) * .83$. Boats with spinnakers with battens or other stiffening devices shall declare that fact to PHRF SEF, and provide the measurements of the Luff, Leech, Foot and SMG. Spinnakers with battens or such stiffening devices will be rated on an individual basis.

OVERSIZED SPINNAKER POLE LENGTH (SPL)

Spinnaker poles longer

than the J measurement Per review of the Board of Handicappers

Typical adjustment is: OSP Oversize spinnaker -3 sec/mile

Oversized Spinnaker Poles defined by the Vessel class racing rules or Yacht designer in which the yachts base rating already factors the oversize spinnaker pole as its base rating are not subject to rating penalties. Proof of such documentation must be submitted by applicant to be exempt of any rating adjustments.

OVERSIZED SPINNAKERS

Oversized Spinnakers..... Per review of the Board of Handicappers

* Note increased effective sail area due to any combination of modification will be reviewed on a case by case basis.

Typical adjustment is: OS Oversize spinnaker -3 sec/mile

Typical adjustment is: OSSP Oversize spinnaker and Pole -6 sec/mile

UNDERSIZED SPINNAKERS

Cruising spinnakers and Flashers. Boats declaring this type of spinnaker as the largest spinnaker available on that vessel through out the year to which the primary measurements are smaller than the symmetric definition may qualify for a rating credit. Provided the following are met.

- ? Not flown from a spinnaker pole
- ? Tacked to the centerline of the boat
- ? Sails where the SMW is smaller than 1.8 x J

Undersized Spinnakers..... Per review of the Board of Handicappers

Dousing socks have no consideration into this rule. No adjustments are made for such devices. Use of such is primary up to the skipper.

ISP ADJUSTMENT

Spinnaker halyard height (ISP) greater than I Per review of the Board of Handicappers

* Note increased effective sail area due to any combination of modification will be reviewed on a case by case basis. An adjusted ISP measurement may fall under the category of Oversized Spinnakers and may fall under multiple sections. Careful review by the Board of Handicappers will determine the correct adjustment.

Typical adjustment is: OS Oversize spinnaker -3 sec/mile

Modification to JC Measurement-

Modification of the JC measurement Per review of the Board of Handicappers

Bloopers are measured as jibs, and must be included in evaluating the LP of the largest jib for handicapping. For more restrictions see Appendix C.

4. PROPULSION

<u>Position</u>	<u>No. of Blades & Type</u>	<u>Sec/Mile</u>
Aperture	3 Solid	+ 6
Aperture	2 or 3 Feathering/Folding	+ 3
Exposed to flow	2 or 3 Feathering/Folding	+ 3
Exposed to flow	2 Solid	+ 6
Exposed to flow	3 Solid	+ 9
Sail Drive	2 or 3 Feathering/Folding	+ 3

To qualify for the Propulsion credit the vessel's base rating must not part of the stock boat in which the base rating was derived.

The base rating of all boats in the PHRF-SEF assumes an inboard or outboard motor on the boat. Such motor must be capable of propelling the boat at 0.85 times the square root of LWL in calm water. Boats not so equipped will incur a -6 second per mile adjustment from their base rating. One design classes are exempt if class rules do not require motors.

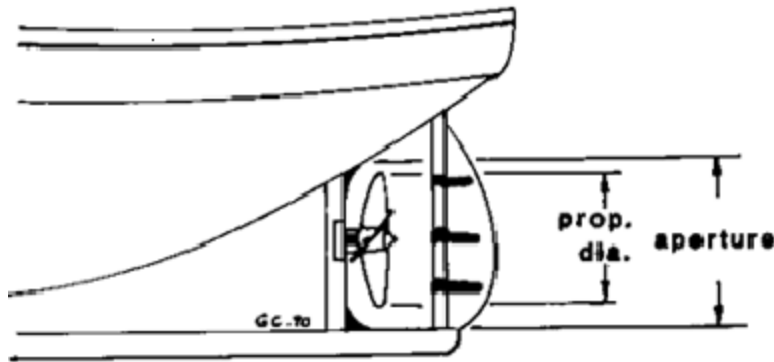

5. MODIFICATIONS/STOCK BOAT

BOAT DESIGN -- SHAPE -- WEIGHT -- INTERIOR EQUIPMENT

REPORTABLE ITEMS OR MODIFICATIONS:

R1) any changes in material, size, or shape (other than fairing to design specifications) of the hull, deck, rudder, or keel.

R2) any canard rudder; other lifting or steering device forward of the keel; or any rudder, steering or stabilizing device added to the boat.

R3) Removal or relocation of any interior or exterior structural components; changes in construction technique/schedule, or changes in materials of bulkheads and/or interior cabinetry, that results in the removal or relocation of weight.

R4) Removal of standard tables, floorboards, headliners, lockers, locker doors, permanent berths, and head enclosures, i.e., you are not allowed to "strip the boat". Cushions, however, are allowed to be removed for racing.

R5) any internal ballast or removal/addition of lead or similar density material. Any moveable ballast, (i.e., water ballast): indicate weight, location, volume, and rate of transfer or discharge.

R6) Dagger boards in addition to keel.

R15. Boats presented for handicapping with ratings from other rules (IOR, IMS, MORC, etc.) must maintain all requirements in equipment, ballasting, and equipment placement specified by those rules or used as a basis for the rating certificate presented. Any deviations from these requirements must be indicated on the rating application and displayed on the certificate.

Notification of modifications must be reported on the application or renewal form. Modification after a rating certificate has been assigned must be reporting by resubmitting another application. Failure to report modifications will result in immediate suspension of the PHRF-SEF certificate. **IF IN DOUBT – REPORT IT.**

Reinstatement of rating will be done only after inspection and/or re-measurement by a PHRF-SEF authorized measurer or handicapper. Violations of this policy or unreported changes may result suspension of a certificate and action under Racing Rules of Sailing Rule 69.

YOUR CURRENT RATING CERTIFICATE BECOMES INVALID AT THE TIME OF THE MODIFICATION. PHRF-SEF WILL ISSUE A NEW CERTIFICATE AFTER REVIEWING THE MODIFICATIONS.

NON-REPORTABLE ITEMS OR MODIFICATIONS:

N1) Fairing to bring the hull, keel or rudder into design specifications. Wet sanding and/or waxing are allowed.

N2) Flexible flaps to fair the skeg into the rudder are allowed provided they do not extend deeper than the skeg.

N3) Water, fuel, and holding tanks maybe emptied as provided by US SAILING. Cushions may be removed. Fuel levels are presumed to be adequate to provide safe passage while to and from port.

Sailboats shall race as rated with at least all the equipment and furnishings supplied as standard equipment by the manufacturer. A sailboat which has altered or removed bulkheads, permanently attached furniture, or structural interior components shall be considered a custom sailboat and rated subject to such. Drawers, headliners, cabinet and locker doors, steps, ladders and engine enclosures shall remain in place as supplied as standard equipment for a sailboat not to be considered a custom yacht.

RIG -- DECK HARDWARE -- EQUIPMENT

REPORTABLE ITEMS OR MODIFICATIONS:

R6) Rig modifications such as, but not limited to:

- a. increase/decrease of mast height, boom length or spinnaker pole length.
- b. spinnaker/whisker poles exceeding 101% of the J dimension.
- c. change in cross-section and/or material or weight of any spar.
- d. addition/elimination of spreaders, shrouds or stays including running backstays, babystays, checkstays, and jumperstruts.
- e. use of cobalt, titanium, boron, carbon fiber in rigs, lifelines or lifeline stanchions.
- f. use of fixed/adjustable bowsprit for flying spinnakers.
- g. carbon or PBO standing rigging.

R7) Headstays, mast stays, and/or partners that are adjustable while sailing, whether accomplished mechanically or hydraulically.

R8) Use of hiking straps, trapeze wires or similar devices that would allow the torsos of the crew or skipper to be extended beyond the beam of the boat.

MISCELLANEOUS

Modifications to hull or rig

Keel

Sec/Mile

Per review of the Board of Handicappers

6. ODR REGULATIONS

One Design Rule (ODR) class regulations:

If your vessel' s base rating was derived by is ODR status then it is presumed thatwhile racing under PHRF-SEF you will be conforming within the class rules.

Any yacht with an ODR defined base rating NOT indenting to honor the Class rules for that vessel must declare such on the PHRF-SEF application. It is also required to define what part(s) of the Class rule(s) will not be in adherence along with the actual deviance.

Sail vessels deviating from the ODR class regulations to which the base rating was derived will be subject for review of the Board of Handicappers for adjustments deemed necessary to bring the yachts back to equality status.

7. CRUISING ACCOMDATIONS

Cruising amenities added to the base boat, such as noted below but not limited to the following, will be taken into consideration with proper documentation provided.

Cruising amenities defined in the yacht design and are part of the base configuration by the Yacht designer are not subject to rating credits. Proof of documentation must be submitted by applicant to be exempt of any rating adjustments.

Items for consideration -

- ? A/C units added to stock boat if not part of the original equipment
- ? Full refrigeration units
- ? Generators added to stock boat if not part of the original equipment
- ? Windless
- ? Battery banks (i.e. group of D8 battery cells)
- ? Dingy Davits
- ? Anchors stowed on deck with full chain ground tackle
- ? Washer and Dryer units
- ? Permanent Bimini Tops of substantial size and weight.

Rating adjustment.....

Per review of the Board of Handicappers

All rating credits and allowances will be noted on the Rating Certificate. Removal of the noted equipment that was used in determining these allowances will invalidate that certificate.

RIG TERMS AND DIMENSIONS:

5.1 FIGURE 5A: Rig Dimensions:

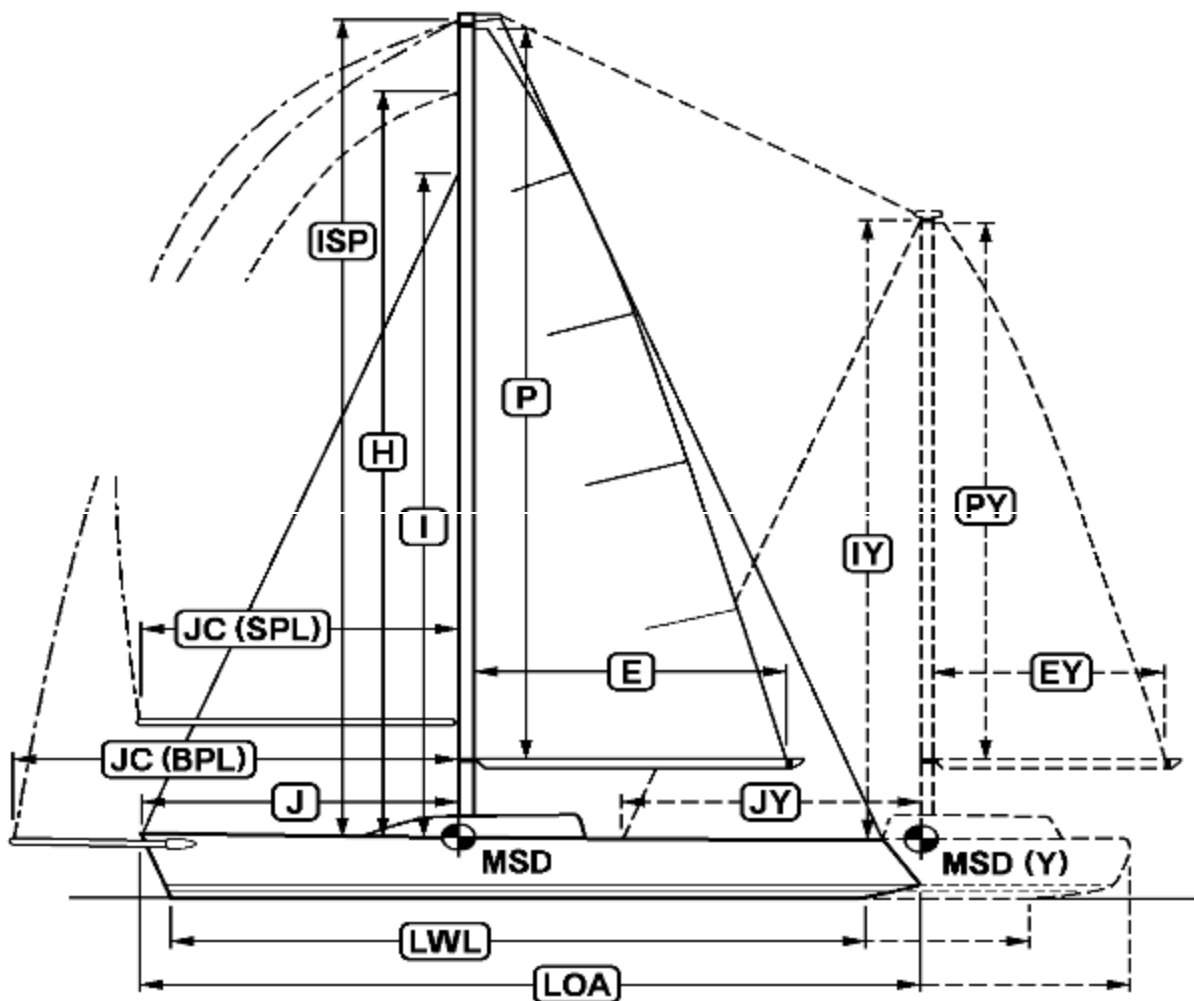

For Standard Class Boats: Rig conditions for double-masted boats

SPL = JC (Pole-Tacked) (with additional applicable dimensions)

BPL = JC (Sprit-Tacked) shown with dashed lines

$ISP \approx I$ (Fractional Spinnakers) $I = ISP$ (Masthead Spinnakers)

For Altered Rigs: H = Altered Spinnaker Hoist

SAIL TERM DEFINITIONS:

HB Measured mainsail headboard length from the after top edge of the headboard to the head measuring point.

HGF Measured headsail foot length from the tack to clew measuring points.

HGM Measured headsail mid-girth (1/2 girth) length from the luff to leech mid-girth measuring points.

HLE Measured headsail leech length from the head to clew measuring points.

HLP Measured headsail perpendicular length from the clew measuring point to the forward edge of the luff.

HLU Measured headsail luff length from the head to tack measuring points.

ME The measured mainsail foot length from the tack to clew measuring points.

MD Measured mainsail diagonal length from the head to clew measuring points.

MGM Measured mainsail mid-girth (1/2 girth) length from the luff to leech mid-girth measuring points.

MGU Measured mainsail upper-girth (3/4 girth) length from the luff to leech upper-girth measuring points.

MGT Measured mainsail top-girth (7/8 girth) length from the luff to leech top-girth measuring points.

MP The LARGER of the measured mainsail luff length from the head to tack measuring points OR the AS-DESIGNED rig dimension, P.

SGF Measured spinnaker foot length from the tack to clew measuring points.

SGL Measured spinnaker lower-girth (1/4 girth) length from the luff to leech lower-girth measuring points.

SGM Measured spinnaker mid-girth (1/2 girth) length from the luff to leech mid-girth measuring points.

SGU Measured spinnaker upper-girth (3/4 girth) length from the luff to leech upper-girth measuring points.

SLU Measured spinnaker luff length from the head to tack measuring points.

SLE Measured spinnaker leech length from the head to clew measuring points.

6.3 SAIL TERM DEFINITIONS:

HB Measured mainsail headboard length from the after top edge of the headboard to the head measuring point.

HGF Measured headsail foot length from the tack to clew measuring points.

HGM Measured headsail mid-girth (1/2 girth) length from the luff to leech mid-girth measuring points.

HLE Measured headsail leech length from the head to clew measuring points.

HLP Measured headsail perpendicular length from the clew measuring point to the forward edge of the luff.

HLU Measured headsail luff length from the head to tack measuring points.

ME The measured mainsail foot length from the tack to clew measuring points.

MD Measured mainsail diagonal length from the head to clew measuring points.

MGM Measured mainsail mid-girth (1/2 girth) length from the luff to leech mid-girth measuring points.

MGU Measured mainsail upper-girth (3/4 girth) length from the luff to leech upper-girth measuring points.

MGT Measured mainsail top-girth (7/8 girth) length from the luff to leech top-girth measuring points.

MP The LARGER of the measured mainsail luff length from the head to tack measuring points OR the AS-DESIGNED rig dimension, P.

SGF Measured spinnaker foot length from the tack to clew measuring points.

SGL Measured spinnaker lower-girth (1/4 girth) length from the luff to leech lower-girth measuring points.

SGM Measured spinnaker mid-girth (1/2 girth) length from the luff to leech mid-girth measuring points.

SGU Measured spinnaker upper-girth (3/4 girth) length from the luff to leech upper-girth measuring points.

SLU Measured spinnaker luff length from the head to tack measuring points.

SLE Measured spinnaker leech length from the head to clew measuring points.

APPENDIX C

A BLOOPER THAT IS FLOWN WITH A SPINNAKER MUST BE:

1. No longer on the luff than the headstay.
2. Tacked to the stem fitting on the bow.

3. The mid-girth measured between the mid-points of luff and leech, shall not exceed 50% of the foot length nor shall the length of any intermediate girth exceed a value similarly proportionate to its distance from the head of the sail.

4. The distance, measured on the surface of the sail, between the midpoint of the foot and midpoint of the luff shall not exceed .55 of the length of the leech.

5. The LP can be no longer than the largest declared headsail.

NOTE: A tack pennant not to exceed 2.5 feet can be added to restriction #1, conforming to the current IOR Blooper rule.